

# How To Use and Enjoy Your Coleman® Kerosene Lantern model 639B700

U.S. PAT. NO. 4,522,582



**Coleman** 

# Parts List For Coleman® Lantern model 639B700

ITEM NO.	PART NO.	DESCRIPTION
1	635-3265	BURNER ASSY.
2	635-3155	BURNER CAP
3	1111	MANTLE
4	639B2992	GENERATOR (K-6)
5	201-5101	PREHEATER CUP
6	288-1621	GENERATOR NUT
7	639-6571	VALVE ASSY.
8	288C1501	KNOB ASSY.
9	201-5511	ALCOHOL BOTTLE
10	220C1401	FUEL CAP
11	639-5151	FOUNT ASSY.
12	242J5201	PUMP PLUNGER ASSY.
13	639-5291	COLLAR AND BOLT
14	635-1151	HEAT SHIELD
15	690-0581	GLOBE
16	635B4231	BAIL HANDLE
17	639A4851	VENTILATOR
18	639-1091	PUMP CUP & NUT

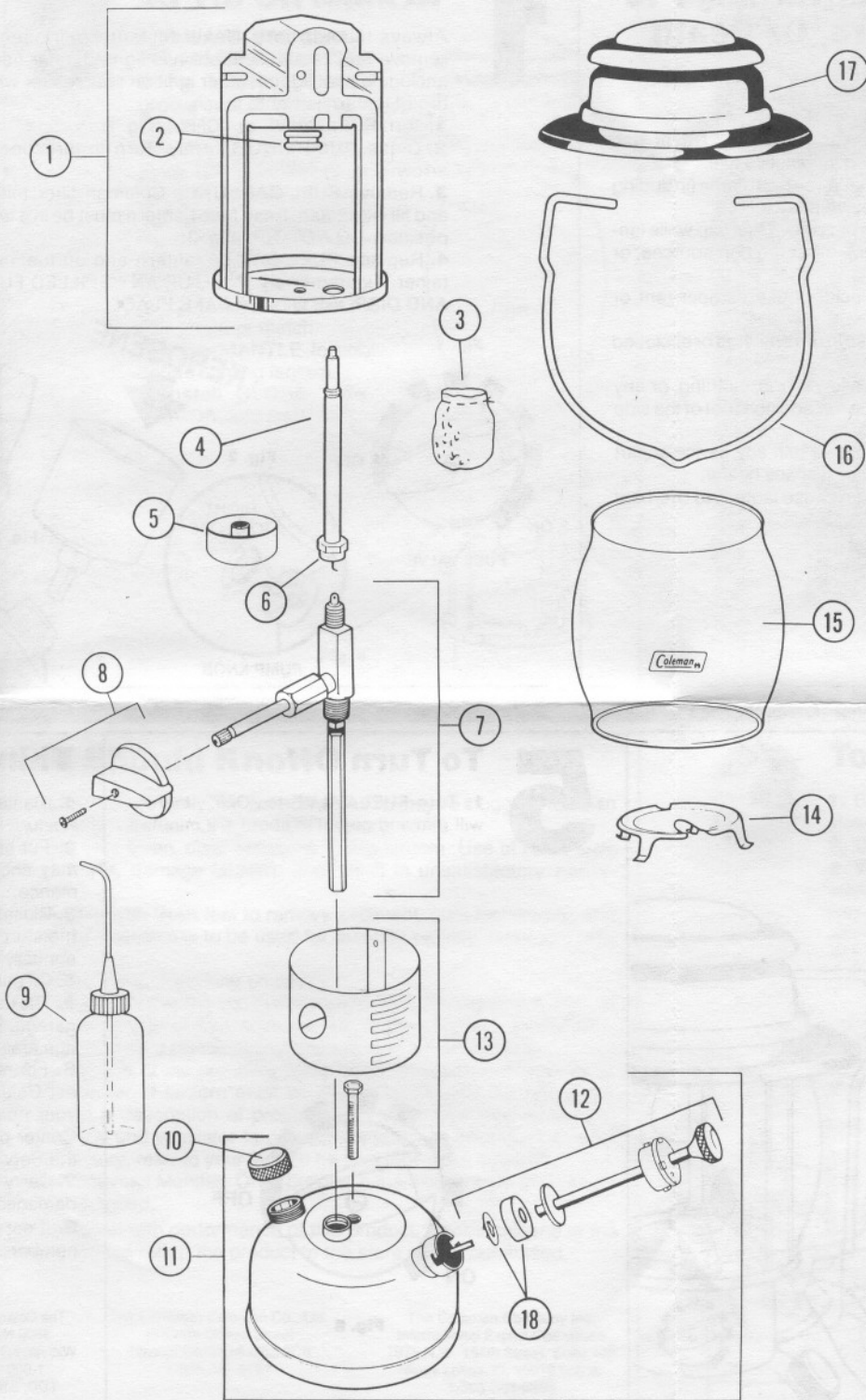

# Generator Replacement

The generator vaporizes fuel. After extended use, deposits may build up inside the generator and make the lantern hard to light or burn dimmer than normal. Replace generator to restore efficiency.

1. Turn FUEL VALVE to "OFF". Remove BAIL HANDLE and VENTILATOR. Remove GLASS GLOBE.
2. Remove HEAT SHIELD.
3. Unscrew CENTER BOLT and lift BURNER from lantern.
4. Unscrew GENERATOR NUT, lift GENERATOR and unhook CLEANING ROD.
5. On new generator, pull CLEANING ROD out about 1/4 inch and re-hook CLEANING ROD. Carefully lower generator to avoid bending cleaning rod.
6. Wrench-tighten GENERATOR NUT to form a leak-tight joint.
7. Replace BURNER making sure PREHEATER CUP is in place and top of generator fits into TOP OPENING in BURNER. Replace CENTER BOLT.
8. Replace HEAT SHIELD.
9. Check MANTLE for damage and replace if needed. Reassemble lantern.
10. Visually check for leak immediately after lighting.

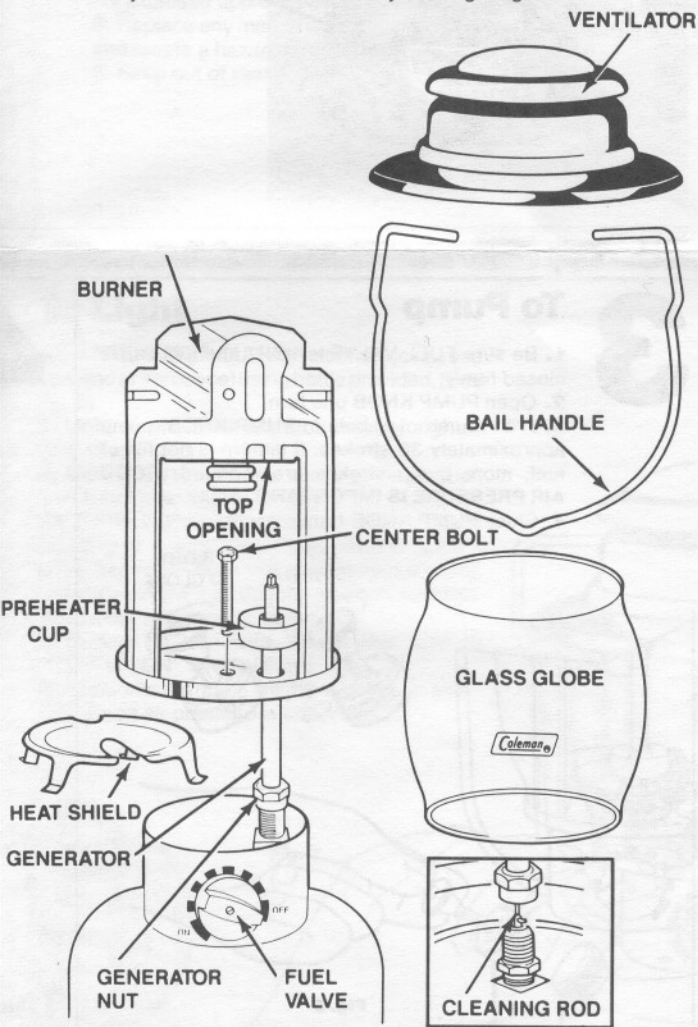

# Follow Instructions And Warnings To Avoid Serious Injury, Fire, Or Death

## **▲ WARNING:**

- 1.** This lantern is designed to use clean, clear kerosene. Never use Coleman fuel, gasohol, regular or premium leaded automotive fuel.
- 2.** Store fuel in a clean, properly marked container away from flame (including pilot lights), other sources of ignition, or excessive heat.
- 3.** Always fill outdoors. Never fill lantern, loosen or remove fuel cap while lantern is lighted, near flame (including pilot lights), other ignition sources, or while top of lantern is hot to touch.
- 4.** Always light and use lantern outdoors; never inside house, camper, tent, or other unventilated or enclosed areas.
- 5.** This lantern consumes air (oxygen). Do not use in unventilated or enclosed areas to avoid endangering your life.
- 6.** Keep lantern away from flammables. Never allow fabric, clothing, or any flammable material to come within four feet of the top and one foot of the side of the lantern.
- 7.** Use for lighting only. Never alter in any way or use with any device or part not expressly approved by Coleman. Do not use as a space heater.
- 8.** Replace any mantle with a hole in it. A hole can cause lantern to overheat and create a hazard.
- 9.** Keep out of reach of children.

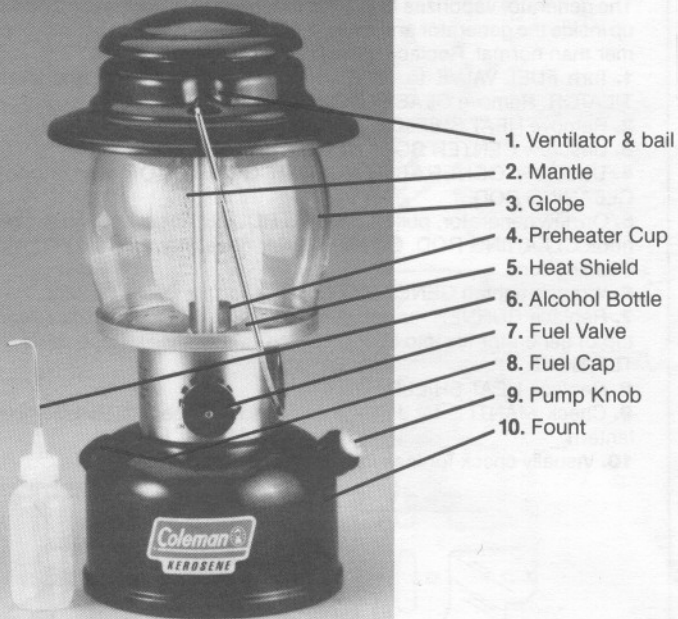

# 1 To Fill

Always fill outdoors. Never fill lantern, loosen or remove fuel cap while lantern is lighted, near flame (including pilot lights), other ignition sources, or while top of lantern is hot to touch.

1. Turn FUEL VALVE to "OFF". (Fig. 1)
2. Close PUMP KNOB firmly. Turn in direction of arrow. (Fig. 2)
3. Remove FUEL CAP. Use a Coleman filter funnel and fill with clean, fresh fuel. Lantern must be in a level position. DO NOT TIP. (Fig. 3)
4. Replace FUEL CAP on lantern and on fuel container. Tighten firmly. WIPE UP ANY SPILLED FUEL AND DISPOSE OF IN A SAFE PLACE.

Fig. 1



Fig. 2

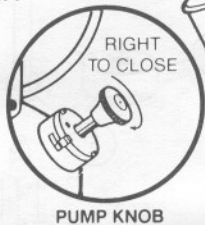

KEROSENE



# 2 To Tie On Mantle

## 1. ALWAYS USE GENUINE COLEMAN MANTLES.

2. Tie MANTLE around groove in BURNER. (Fig. 4) Distribute folds of MANTLE evenly. Cut off surplus string 1/4" from knot.

3. Light bottom of MANTLE evenly. Burn until nothing but white ash remains. Once the MANTLE has been burned it is very fragile. Be careful not to touch it with finger or match.

4. Allow MANTLE to cool before lighting lantern.

5. Install GLOBE, VENTILATOR, and BAIL.

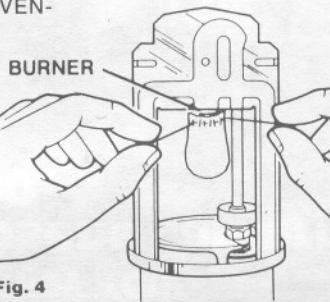
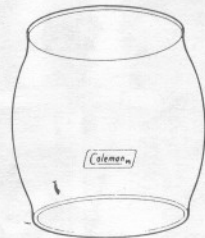

# 3 To Pump

1. Be sure FUEL VALVE is "Off" and fuel cap is closed firmly.
2. Open PUMP KNOB one turn.
3. With thumb over hole in PUMP KNOB, pump approximately 30 strokes. If lantern is not full of fuel, more pump strokes are required. **GOOD AIR PRESSURE IS IMPORTANT.**
4. Close PUMP KNOB firmly.

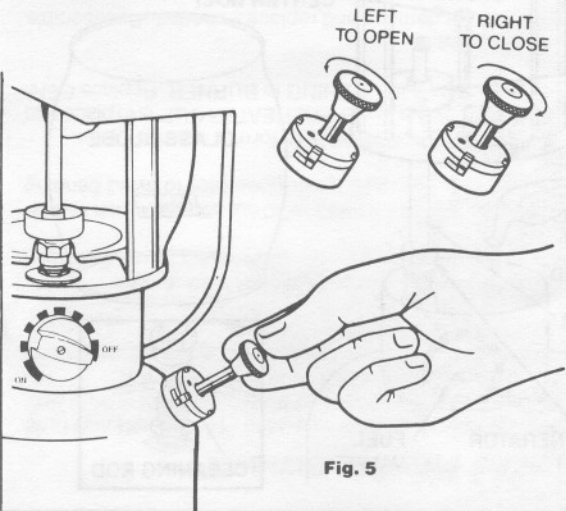

# 4 To Light

1. Fill PREHEATER CUP with alcohol (do not use gasoline or kerosene) using bottle provided. (See Fig. 6)
  2. Light alcohol with a match through lighter hole. (See Fig. 7)
  3. Allow flame to consume nearly all the alcohol, then turn FUEL VALVE to "ON".
- CAUTION:** Flames other than at mantle indicate flooding or a leak. Turn FUEL VALVE "OFF", allow flames to burn out and lantern to cool. Carefully review instructions and correct problem before relighting lantern.
4. To clean tip, turn FUEL VALVE from "ON" to "OFF" to "ON" several times.
  5. Additional pumping will be required at intervals. Good air pressure is important.

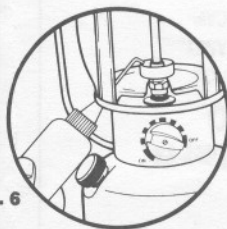
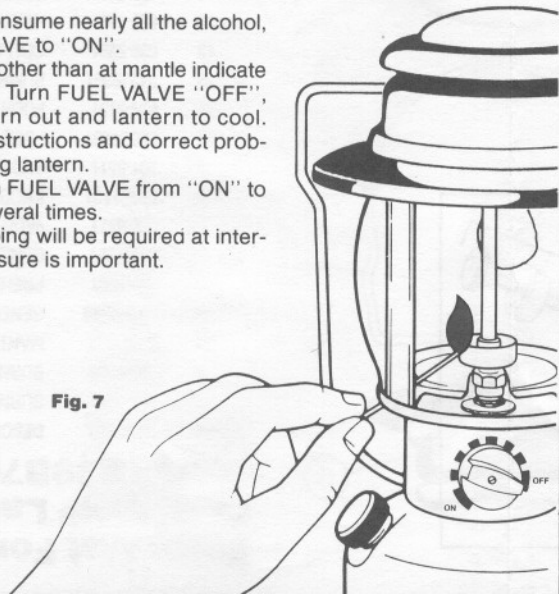

Fig. 7



# 5

## To Turn Off

1. Turn FUEL VALVE to "OFF". Light will dim and go out in about 1-2 minutes.



Fig. 8

## Things You Should Know

1. If lantern lights poorly or burns dimly, the generator gas tip may be clogged. To clean tip, turn FUEL VALVE from "ON" to "OFF" to "ON" several times.
2. For best results, use only clean, clear kerosene in this lantern. Use of other fuels may shorten generator life, damage lantern, and result in unsatisfactory performance.
3. Rinse tank occasionally with fresh fuel to remove sediment, gum formations, and moisture accumulations. If lantern is to be used for standby service, rinse and refill annually with fresh fuel.
4. Oil pump periodically to keep it working smoothly.
5. The usual storage areas for camping and picnic equipment is the basement, attic, or garage. To avoid the accumulation of dust, cobwebs, etc. that is common in these storage areas, place your lantern in a plastic bag and seal it with a rubber band.
6. For repair service call one of the numbers listed below for location of your nearest Coleman Service Center. If lantern must be mailed to Service Center, attach your name, address, and a description of problem to product and mail to Service Center prepaid, less globe and ventilator to prevent breakage. If necessary to write the Service Center or factory, refer to your lantern by specific model number.
7. Carry a spare set of Coleman Mantles. Once burned, a mantle is fragile and can be damaged if touched or dropped.
8. If not completely satisfied with performance of this product, please call one of the numbers listed below. Do not return the product to the store where purchased.

The Coleman Co., Inc.  
3600 N. Hydraulic  
Wichita, KS 67219 U.S.A.  
1-800-835-3278  
TDD: 316-832-8707

The Canadian Coleman Co., Ltd.  
15 North Queen Street  
Toronto CANADA M8Z 2C6  
1-800-387-6161

The Coleman Company Inc.  
International Export Operations  
7975 N.W. 154th Street, Suite 440  
Miami Lakes, FL 33016 U.S.A.  
1-305-362-6868



1 800 835-3278 USA 1 800 387-6161 CDN

Made in United States of America

**THE COLEMAN COMPANY, INC.**

General Office and Factory: Wichita, Kansas U.S.A. 67219

639A050 (7/97) P.I.

LITHO IN U.S.A.